

Manufacturer of sand cleaners

PAMS S.A.S

6 rue des Artisans
Zone Artisanale
40480 Vieux-Boucau-les-Bains
FRANCE
Tel : +33 (0) 5 58 48 15 31
Email : contact@canicas.fr



www.canicas.fr

SALES REPRESENTATIVE

Thierry HELBRINGER
Mobile : +33 (0) 6 11 71 03 46
thierry.helbringer@canicas.fr
thierry.helbringer@gmail.com



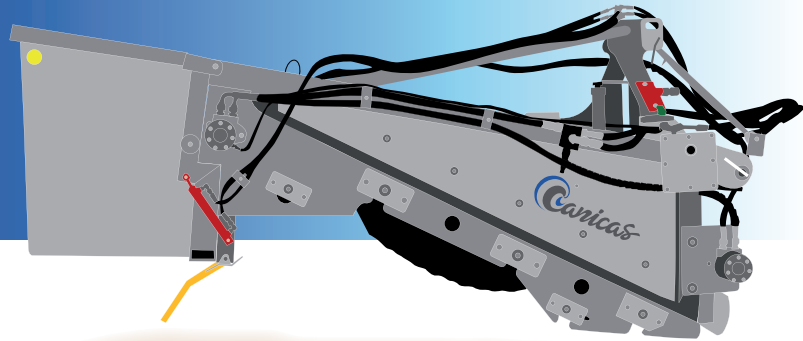

Very easy to steer and effective for all beach conditions :

Ideal for confined and rough areas.

Designed for cleaning narrow, sloppy and serviced beaches (with play area, beach furniture, umbrellas, etc.). Highly versatile. Effective for large and medium-sized beaches, thanks to its working width (1,7 m) (77").

A simple, robust and reliable design, to cut your operating costs :

Hot galvanizing, by dipping the frame and assemblies, for the best possible protection against corrosion.

High-quality steels, sized to stand the beach working conditions in the long run.

Very little maintenance required.

Hydraulic system: powerful, simple, reliable and secured.

Specifications

Length :	2 530 mm (100")
Width :	2 170 mm (85") (Smoother-finisher)
Overall height :	1 250 mm (49") (Laid on the ground)
Weight empty :	620 kg
Hopper capacity :	600 liters
Dump height :	Up to 1 400 mm (Depending on the tractor's size)
Number of vibrating rollers :	2
Hydraulic tank :	40 liters (integral with the frame)
Sound level :	< 70 dB
Drive :	Hydraulic pump and motors for driving the screening belt and beater
Anticorrosion treatment :	Hot galvanizing by dipping the frame and the various parts (hopper, lifting system, beater, etc.). This ensures the best protection, including the bore of tubular parts).

Performance

Working width :	1 700 mm (67") (Up to 1 900 mm (75") optionally)
Working depth :	0 to 180 mm (7")
Can be used on dry or wet sand	
Type of waste :	Seaweeds, reeds, wood, plastics, cans, rubble, glass, large debris.
Area performance :	up to 15 000 m² / hour (150,000 sq. ft / h) (depending on beach conditions)

Optional equipment

- Two-component paint applied on hot-galvanized steel by dipping
- Hydraulic hourmeter
- Cab-operated screening belt rotation-reverser
- Other options (Refer to customer service)

Tractor requirements

- Recommended power: from 70 HP / 4 driving wheels
- Tires: recommendations defined according to the tractor model
- Coupling: rear lift-arm and 3-point hitch
- Hydraulic cylinders: 2 double-acting
- Power takeoff: 6 grooves 3/8" 540 RPM

In our workshops located on the Aquitaine littoral, we have manufactured machines for cleaning beaches and sandy areas (hippodromes, riding centers, water treatment basins, agricultural areas, etc.) for more than 25 years.

Thanks to our close proximity to the littoral environment, along with our large customer base around the world and our passion for innovation, «Canicas» is now a brand of reference well-known for its robustness, reliability and performances.

A company close to its customers, and high-quality services:

- A constant supply of spare parts
- An after-sale service provided by our skilled technicians
- Fast response times ensured by our workshop trucks or tool-carrier trucks in France, and by our distribution network abroad.
- Rental of machines.
- Loan of machines in the event of accidental damage to cope with machine downtime.

Our company reserves the right to change at any time the products proposed to and referenced by our customers, without notice and without entitling the reader to damage or interest.

